

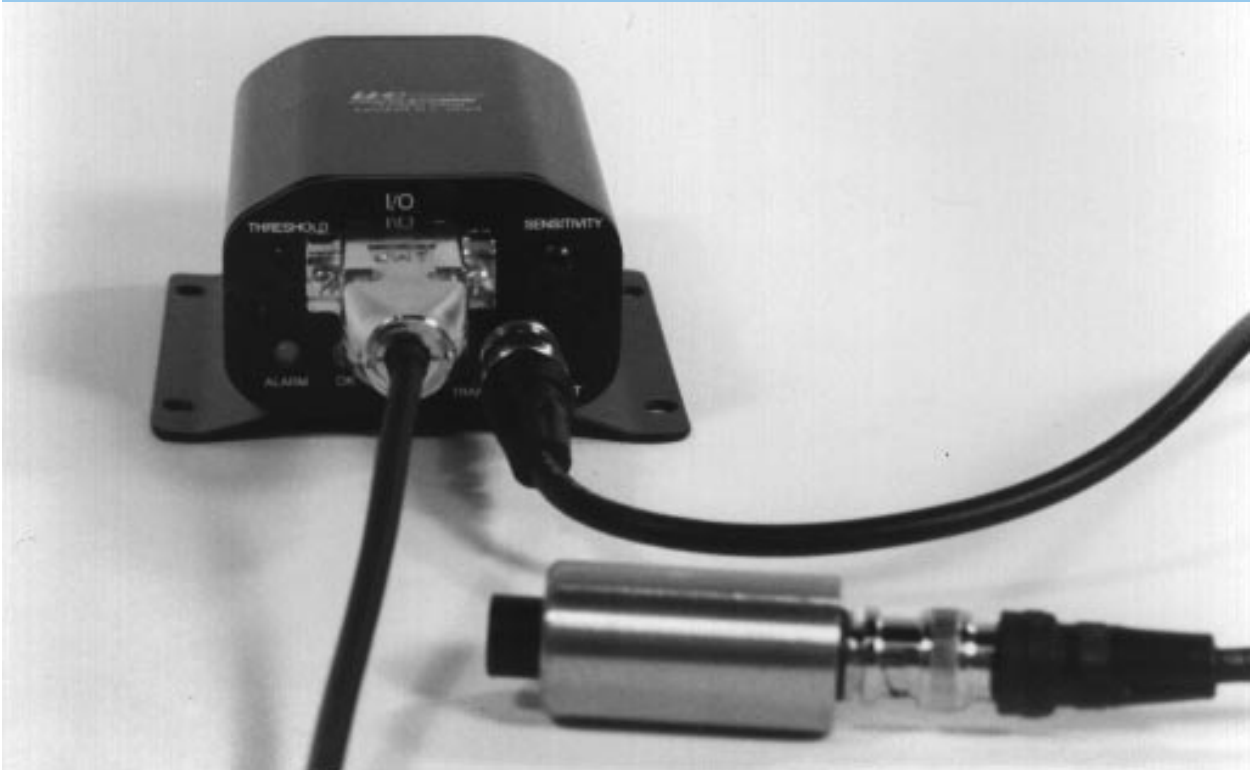

# UCA 586

## Ultrasonic Condition Alert

with ULTRATREND OUTPUT



Ultrasonic Condition Alert

**THE ULTRASONIC CONDITION ALERT**  
*(high frequency vibration transducer)*  
constantly monitors changes in ultrasonic emissions produced by operating equipment and fluid flows. It has a broad range of applications since practically anything that produces ultrasound can be monitored.

Applications include:

- Bearing Failure Warning
- Cavitation Warning
- Flow/No-Flow Warning
- Valve By-Pass



## How The UCA Works

The Ultrasonic Condition Alert senses a narrow range of high frequency vibrations. As a change in amplitude occurs, the event is noted as either an increase or decrease in voltage. This change is noted through either a 4-20 mA or 0-10 VDC output, which is directly proportional to the received signal. An Ultrasonic Condition Alert can monitor for an increase in amplitude, a decrease in amplitude or may even be set up to “count” ultrasonic events.

## Unique Features

Each UCA comes with an adjustable sensitivity and an adjustable threshold level. In addition, each UCA can be configured to provide a demodulated or “heterodyned” output through UE Systems exclusive Ultratrend™. Ultratrend is an advanced ultrasonic filtration process that provides accurate signal detection and sound wave translation. This demodulated output is ideally suited for spectral analysis and can be connected to a computer or vibration analyzer as well as a recording device, speaker or headphone.

Every UCA comes complete with transducer, epoxy mountable threaded fittings, cable, LED local alarm indicator, local LED power indicator, sensitivity adjust, threshold adjust and output cable with 4-20 mA, 0-10 VDC, open collector alarm and ultrasound demodulated signal termination capability.

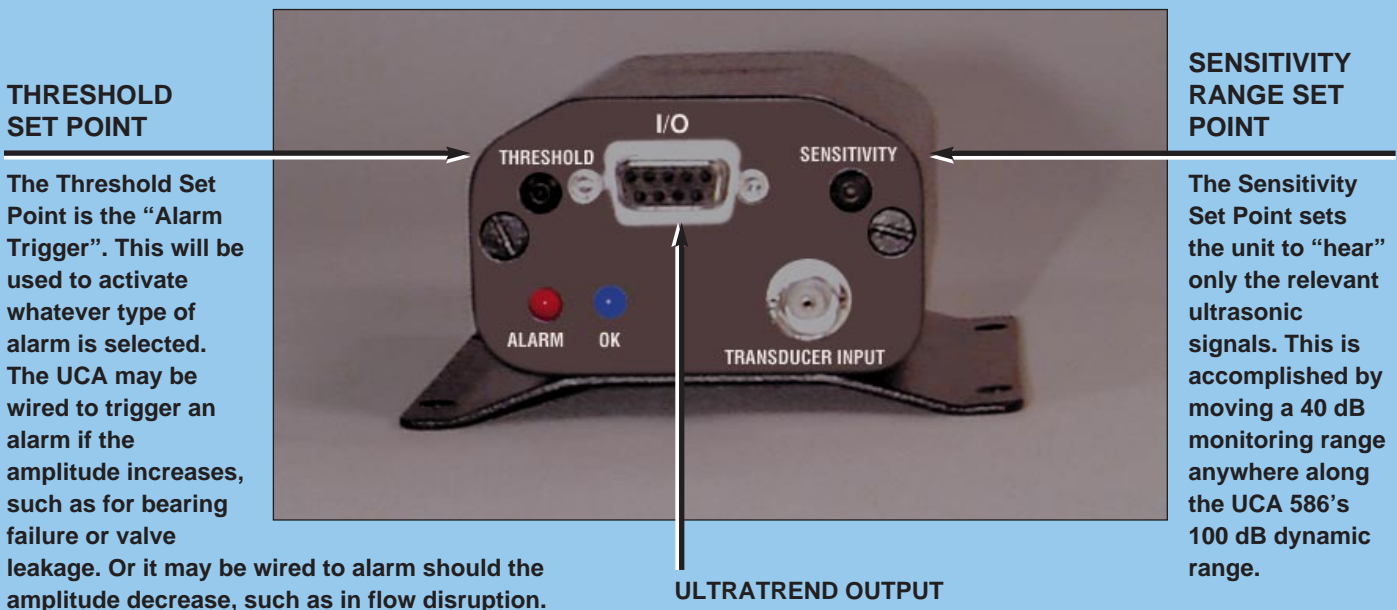

## Additional Applications

- Onset of rubbing conditions
- Lubrication starvation warning
- Power disruption alarm
- Solids flow monitoring
- Safety valve, rupture disc monitoring
- Screw compressor bearing monitoring
- Air handling/fan bearing monitoring
- Valve blockage



Valve flow / no flow condition monitoring.

# Specifications:

**Frequency Range:** 25-50 kHz

**Outputs:** 4-20 mA DC Linear Output

Transfer Function: dB/mA DC  
 Scale: 1 mA DC = 2.5 dB input Level  
 Dynamic Measurement Range: 40 dB  
 (set anywhere along the 100 dB input range)

0-10 DC V Linear Output

Transfer Function: dB/VDC  
 Scale: 1 VDC = 4 dB input level  
 Dynamic Measurement Range: 40 dB  
 (set anywhere along the 100 dB input range)

**Alarm:** Open collector rated @ 24 VDC, 10 mA  
 Threshold Level: Adjustable over the output range. Alarm output stops conducting when input level exceeds the threshold level (set point)

**Heterodyned (Audio) Output:**

90 dBA at full scale output into 16 ohms  
 3 dB bandwidth approx. 6 kHz

**Threshold Setting:**

Low impedance output which senses the threshold setpoint (set point)

**Dynamic Input Range:** Approx. 100 dB

**I/O Cable:** RF shielded. Length: 6 ft. (1.82 m)

**I/O Connector:** DB9

**Transducer Input Connector:** BNC

**Panel Adjustments:** Sensitivity and threshold

**Power Indicator:** Blue LED

**Alarm Indicator:** (local) Red LED

# Environmental & Physical Specifications

**Enclosure\*:** Aluminum

Dimensions:  
 4.3"x3.7"x 1.9" (LWH)  
 (10.9 x 9.4 x 4.8 cm)

Operating Temperature:  
 32°F - 140°F (0°- 60° C)

Weight:  
 13.5 oz (.38 kg)

**Transducer:** Piezo Electric,  
 stainless steel housing with  
 Female BNC connector  
 Dimensions: Dia: 1.0" (2.54 cm)  
 Length: 2.4" (6.1 cm)  
 Thread: (female) 10/32

**Warranty:** 1 year parts/labor

\* Note: Can be easily mounted in standard NEMA enclosures

Specifications subject to change without notice.

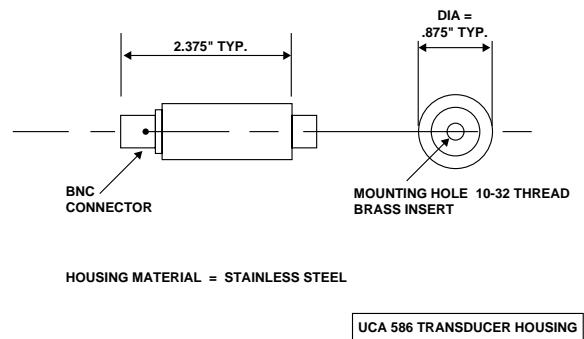
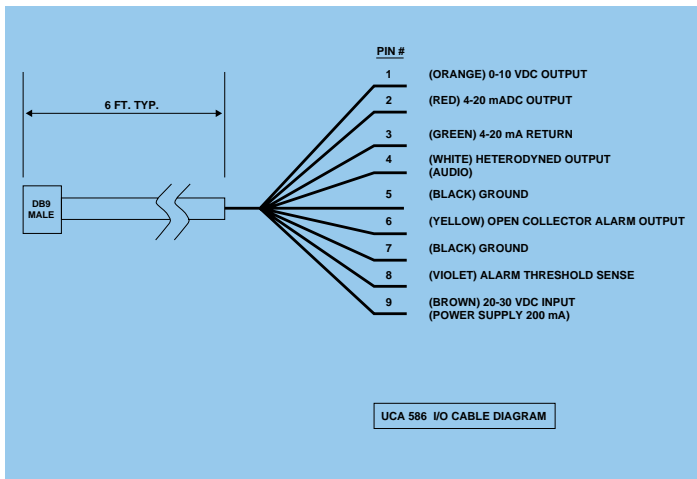
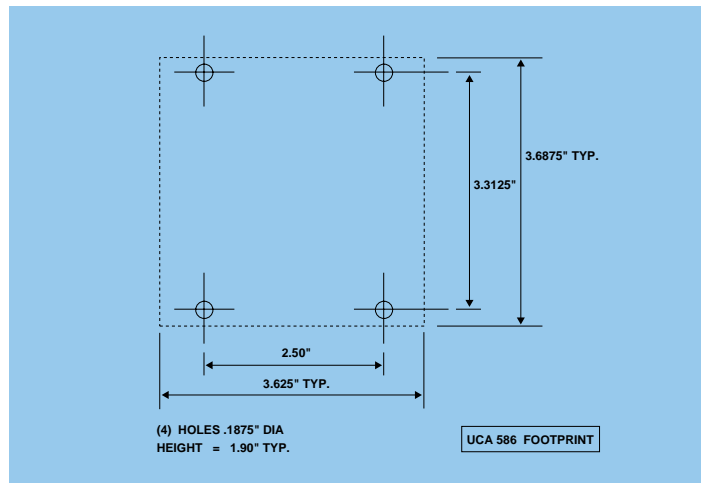



Monitor bearing conditions.



UCA has local alarm and power indicators.



Safety valve leaks.

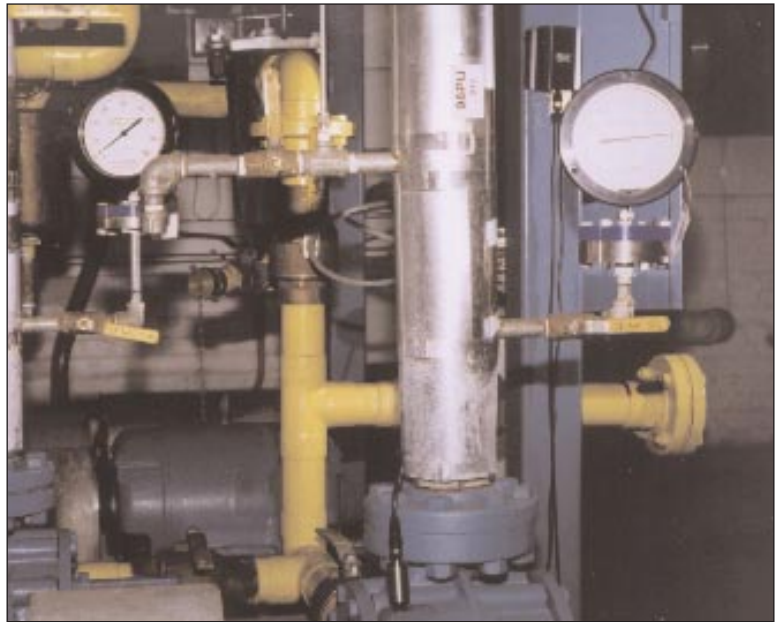

Destructive cavitation alert.



A Proud Member of:

The **ue** Group



Quality Instruments • Quality Training Services  
Quality Inspection Services • Quality Support